

# HYDRAULIC-TYPE HIGH SPEED RAISING MACHINE

MODEL:CL-0-1800~2500

ROLLERS:24

1. Adjustment Device
2. Swivel Device
3. Automatic Fabric Centering Device
4. Expanding Roller Device
5. Raising Device
6. Clearing Brush Roller
7. Fluff Collecting Device
8. Oil Tank
9. Plaiting Device
10. Static Eliminator

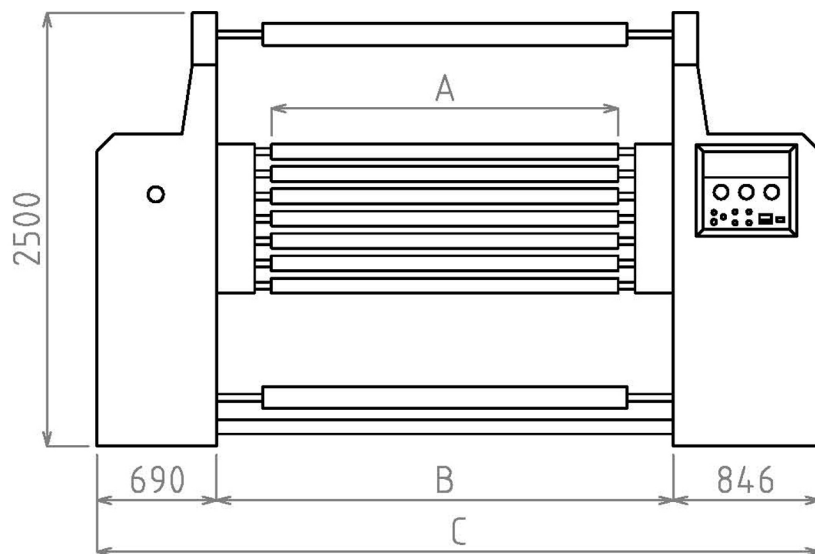
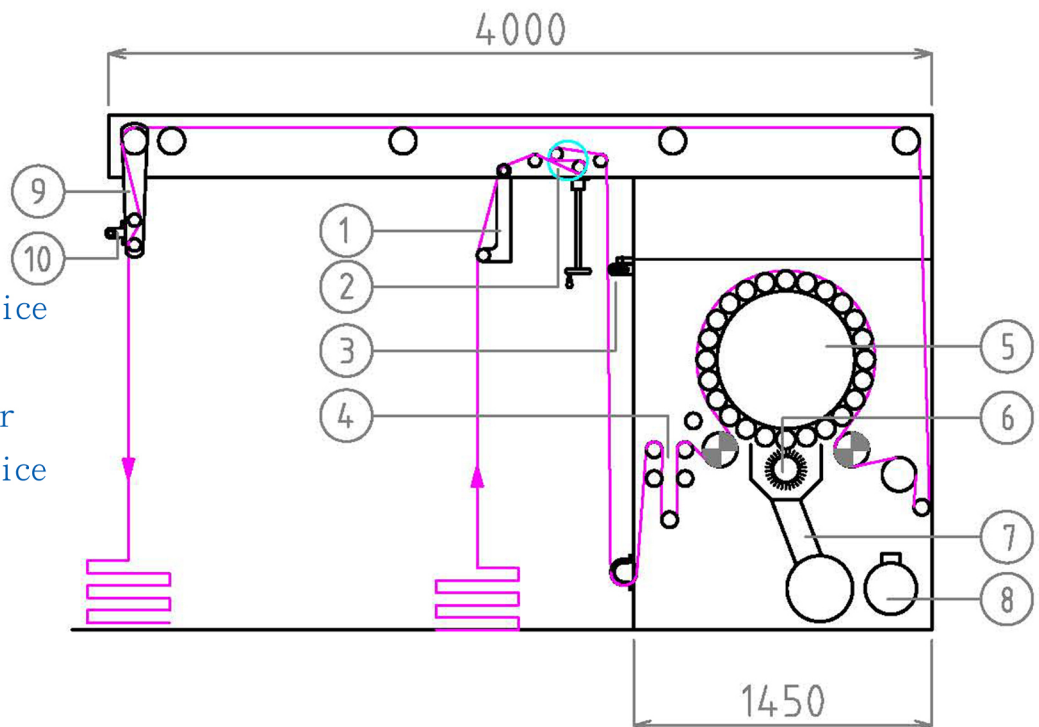

A	1800	2000	2300
B	2434	2634	2934
C	3970	4170	4470

Unit : mm

The manufacturer reserves the right to change or modify the specify the specifications as mentioned in this catalogue without prior notices to any party concerned



鍵輪機械廠有限公司  
CHIEN LUN MACHINERY CO., LTD.  
東亞齒輪機械廠有限公司  
TUNG YA GEAR MACHINE MFG. CO., LTD.

台灣台北縣三重市竹圍街28-7號  
NO. 28-7, Chu Wei St., Sanchung, Taipei Hsien, Taiwan  
TEL:886-2-2973 1344(Rep.) FAX:886-2-2972 2014  
E-mail:tyco8@ms64.hinet.net